

VENTILADORES A TRANSMISIÓN MONTADOS CUBIK REFORZADO

Conjunto montado de:

- Ventilador Cubik reforzado
- Polea motor canal SPB
- 2 o 3 correas (según potencia)
- Carriles tensores soldados
- Polea ventilador canal SPB.
- **Código inicio: CV03403.**

Detalle montaje MOTOR (indicar posición deseada):

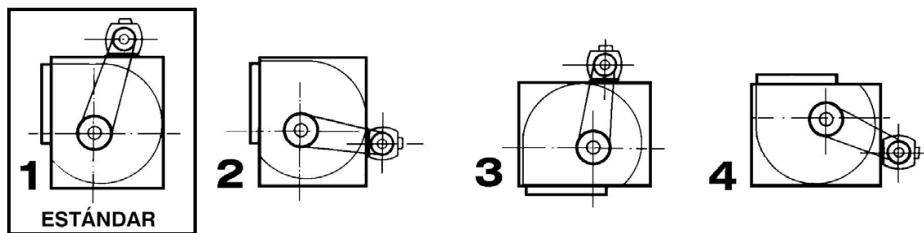

Poleas lado derecho (visto impulsión)

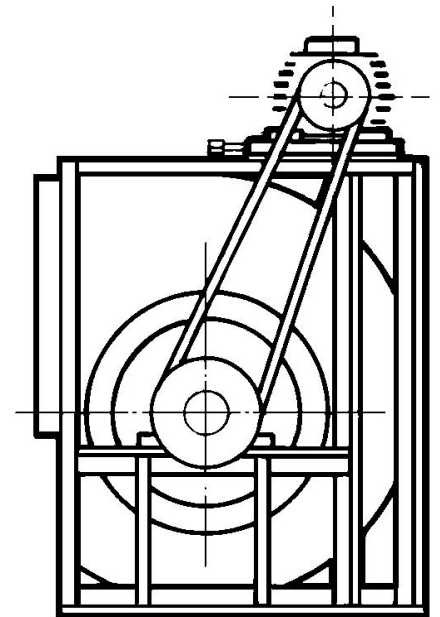

CARACTERÍSTICAS TÉCNICAS:

Código	Modelo	Potencia motor (CV)	Velocidad (r.p.m)	Intensidad máxima admisible (A)			Temperatura del aire (°C)		Peso (Kg)
				230V	380V	660V	mín	máx.	
CV03403	BS 20/20	3	500	8,80	5,09	2,93	-20	80	135,2
CV03404	BS 20/20	4	650	11,77	6,81	3,92	-20	80	140
CV03405	BS 20/20	5,5	650	15,02	8,70	5,01	-20	80	147,6
CV03406	BS 20/20	7,5	1000	20,05	11,61	6,68	-20	80	160,4
CV03413	BS 22/22	3	400	8,80	5,09	2,93	-20	80	139,1
CV03414	BS 22/22	4	500	11,77	6,81	3,92	-20	80	143,9
CV03415	BS 22/22	5,5	580	15,02	8,70	5,01	-20	80	151,5
CV03416	BS 22/22	7,5	650	20,05	11,61	6,68	-20	80	164,3
CV03417	BS 22/22	10	700	26,62	15,41	8,87	-20	80	176,3
CV03424	BS 25/25	4	450	11,77	6,81	3,92	-20	80	172,5
CV03425	BS 25/25	5,5	450	15,02	8,70	5,01	-20	80	180,1
CV03426	BS 25/25	7,5	500	20,05	11,61	6,68	-20	80	192,9
CV03427	BS 25/25	10	550	26,62	15,41	8,87	-20	80	204,9
CV03429	BS 25/25	15	600	37,54	21,73	12,51	-20	80	241,8
CV03430	BS 25/25	20	650	51,18	29,63	17,06	-20	80	267,8
CV03435	BS 30/28	5,5	300	15,02	8,70	5,01	-20	80	221,7
CV03436	BS 30/28	7,5	350	20,05	11,61	6,68	-20	80	234,5
CV03437	BS 30/28	10	400	26,62	15,41	8,87	-20	80	246,5
CV03439	BS 30/28	15	400	37,54	21,73	12,51	-20	80	283,4
CV03440	BS 30/28	20	450	51,18	29,63	17,06	-20	80	309,4

DIMENSIONES VENTILADORES (mm):

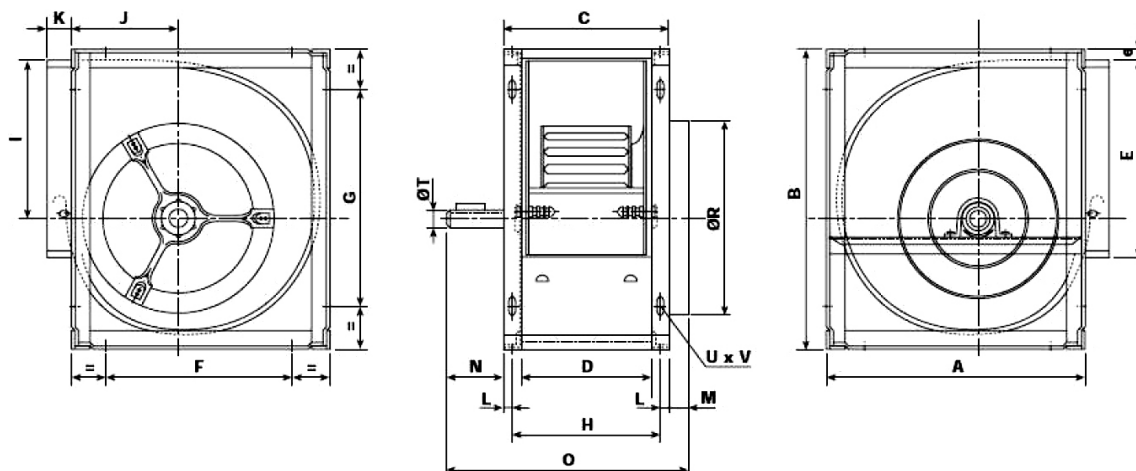

Modelo	A	B	C	D	E	F	G	H	I	J	K	L	M	N	P	Q	S	T	Ø
BS 20/20	772	967	630	630	526	340	361	50	50	635	830	680	20	13	50	730	85	900	35
BS 22/22	853	1058	700	700	580	390	397	55.1	50	710	745	745	20	13	50	795	82,5	960	35
BS 25/25	950	1193	796	800	651	430	436	55.5	50	813	1056	846	20	13	50	896	82	1060	35
BS 30/28	1145	1410	870	945	759	485	512	55	50	1016	1273	1273	20	13	50	970	115	1200	40

DIMENSIONES MOTORES (mm):

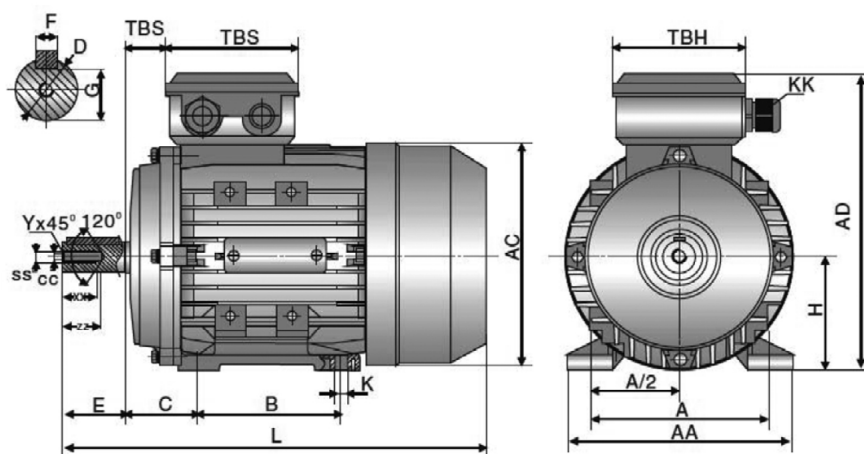

Potencia motor	H	A	B	C	D	E	F	G	K	AA	AD	AC	L	LCC
15 CV - 20 CV	160	254	210/254	108	Ø42	110	12	37	15X19	290	390	Ø320	640	652
10 CV	132	216	178	89	Ø38	80	10	33	12X16	252	325	Ø270	474/500	484/540
7,5 CV	132	216	140	89	Ø38	80	10	33	12X16	252	325	Ø270	436	468
5,5 CV	112	190	140	70	Ø28	60	8	24	12X16	220	292	Ø230	395	410
3 CV - 4 CV	100	160	140	63	Ø28	60	8	24	12X16	196	252	Ø205	368	392

LCCL	LCA	KK	TBS	TBW	TBH	SS	XX	ZZ	CC	Y
652	794	2-M32X1,5	64	143	146	M16	35	42	14,2	2
564/590	648/674	2-M25X1,5	38	119	119	M12	28	32	10,2	1,5
553	636	2-M25X1,5	38	119	119	M12	28	34	10,2	1,5
483	455	2-M25X1,5	32	119	119	M10	22	28	8,5	1,5
474	445	2-M20X1,5	26	105	105	M10	22	28	8,5	1,5