

CAJAS VENTILACIÓN 400°/2H

SERIE XBP-MU



CARACTERÍSTICAS TÉCNICAS

- Ventilador en chapa de acero galvanizado.
- Turbina con palas hacia delante en chapa de acero galvanizado.
- Accionado a transmisión por correas y poleas, fuera del flujo del aire.
- NO incluye base tensora

Motor:

- Trifásico 230/400 V. 50 Hz hasta 4 kW, motores de más potencia 400/690 V. 50 Hz
- IE3 desde potencias de 0,75 kW. Clase F
- Rodamiento a bolas, protección IP55
- Certificado para trabajar fuera de la zona de riesgo a 400° durante 2 horas
- En continuo máximo 120 °C.

Bajo demanda:

- Fabricación especial con salida vertical.

 Certificado
Applus+

Si no se indican datos de presión estática o revoluciones del ventilador, se suministra la configuración estándar de 15/20 mm c.d.a. (200 Pa).

Código	Descripción	Intensidad máxima (A)			Peso (kg)	Caudal máx. (m³/h)
		230 V	400 V	690 V		
VE10451	XBP-MU 400°/2H 9/9 0,37 KW (1/2 CV)	2,00	1,20	-	66	3.300
VE10452	XBP-MU 400°/2H 9/9 0,55 KW (3/4 CV)	2,90	1,69	-	69	3.800
VE10453	XBP-MU 400°/2H 9/9 0,75 KW (1 CV)	2,80	1,62	-	74	4.250
VE10454	XBP-MU 400°/2H 9/9 1,1 KW (1,5 CV)	4,07	2,30	-	84	4.800
VE10455	XBP-MU 400°/2H 10/10 0,55 KW (3/4 CV)	2,90	1,69	-	81	4.000
VE10456	XBP-MU 400°/2H 10/10 0,75 KW (1 CV)	2,80	1,62	-	86	4.350
VE10457	XBP-MU 400°/2H 10/10 1,1 KW (1,5 CV)	4,07	2,30	-	96	5.000
VE10458	XBP-MU 400°/2H 10/10 1,5 KW (2 CV)	5,40	3,11	-	102	5.450
VE10459	XBP-MU 400°/2H 12/12 0,75 KW (1 CV)	2,80	1,62	-	105	5.250
VE10460	XBP-MU 400°/2H 12/12 1,1 KW (1,5 CV)	4,07	2,30	-	115	6.150
VE10461	XBP-MU 400°/2H 12/12 1,5 KW (2 CV)	5,40	3,11	-	121	6.600
VE10462	XBP-MU 400°/2H 12/12 2,2 KW (3 CV)	7,90	4,60	-	108	7.600
VE10463	XBP-MU 400°/2H 15/15 1,1 KW (1,5 CV)	4,07	2,30	-	142	8.050
VE10464	XBP-MU 400°/2H 15/15 1,5 KW (2 CV)	5,40	3,11	-	149	8.900
VE10465	XBP-MU 400°/2H 15/15 2,2 KW (3 CV)	7,90	4,60	-	136	10.100
VE10466	XBP-MU 400°/2H 15/15 3 KW (4 CV)	10,70	6,15	-	149	11.350
VE10467	XBP-MU 400°/2H 15/15 4 KW (5,5 CV)	13,90	8,00	-	149	12.600
VE10468	XBP-MU 400°/2H 18/18 2,2 KW (3 CV)	7,90	4,60	-	171	15.850
VE10469	XBP-MU 400°/2H 18/18 3 KW (4 CV)	10,70	6,15	-	182	17.600
VE10470	XBP-MU 400°/2H 18/18 4 KW (5,5 CV)	13,90	8,00	-	184	19.450
VE10471	XBP-MU 400°/2H 18/18 5,5 KW (7,5 CV)	-	10,30	5,97	211	21.350

ACCESORIOS

Tapa ciega para aspiración serie XBP-MU

Código	Modelo
VE10480	Tapa ciega aspiración XBP-MU 9/9
VE10481	Tapa ciega aspiración XBP-MU 10/10
VE10482	Tapa ciega aspiración XBP-MU 12/12
VE10483	Tapa ciega aspiración XBP-MU 15/15
VE10484	Tapa ciega aspiración XBP-MU 18/18



DIMENSIONES (mm)

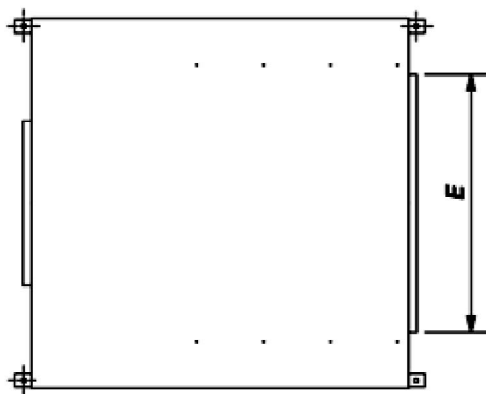
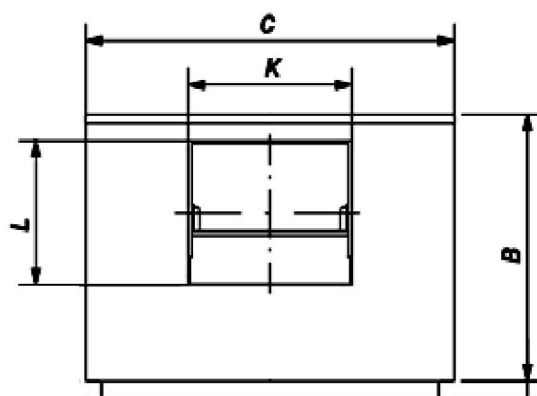
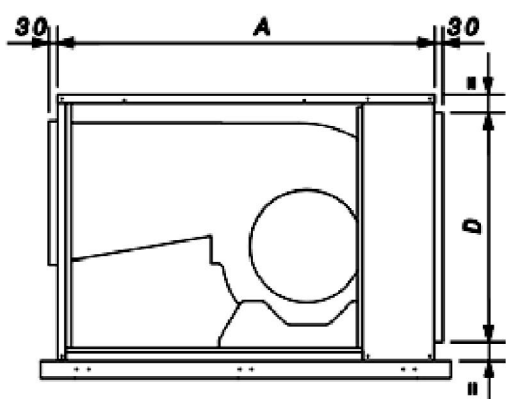

Código	Modelo	A	B	C	D	E	K	L
VE10480	XBP-MU-9/9	785	592	759	426	454	310	270
VE10481	XBP-MU-10/10	860	618	825	479	504	334	296
VE10482	XBP-MU-12/12	970	680	945	554	604	395	350
VE10483	XBP-MU-15/15	1100	776	1100	659	704	483	411
VE10484	XBP-MU-18/18	1278	900	1250	779	904	552	486

CURVAS CARACTERÍSTICAS

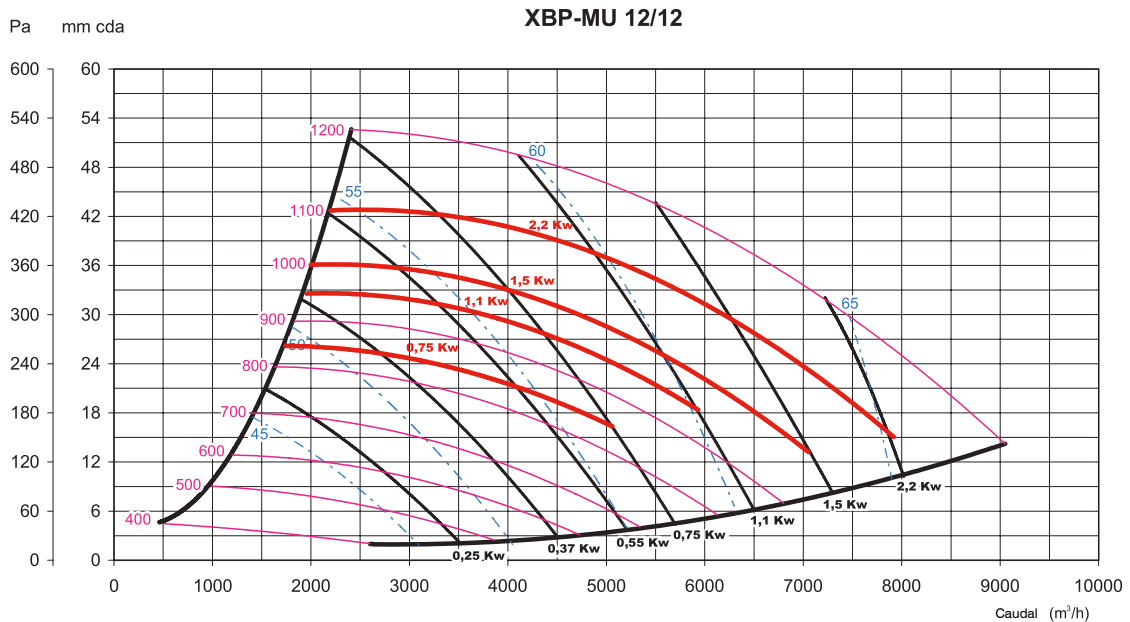
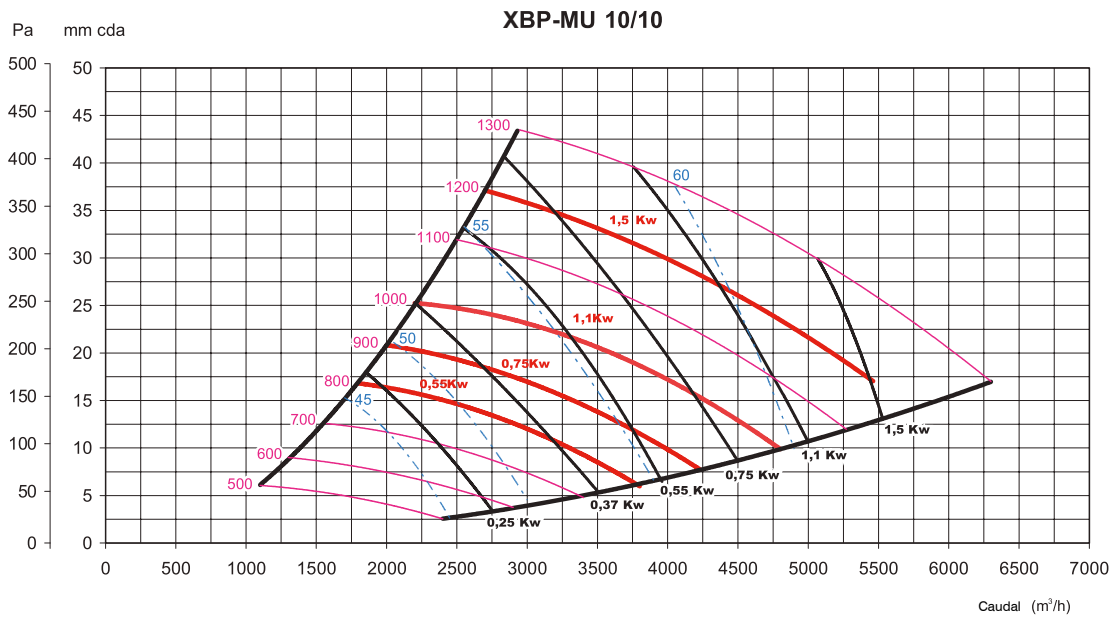
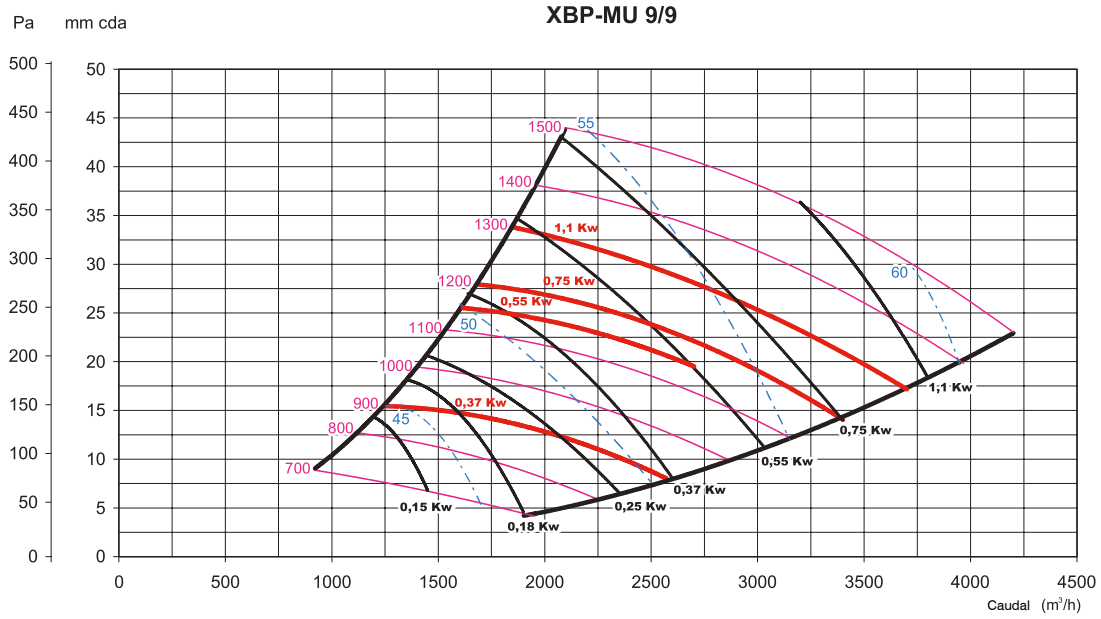

CURVAS CARACTERÍSTICAS

