

SAR

Unidad de recogida y bombeo



- Utilizo doméstico
- Utilizo agrícola
- Utilizo civil



Código: AC44550_AC44555

CAMPO DE PRESTACIONES

50 Hz n= 2900 min⁻¹

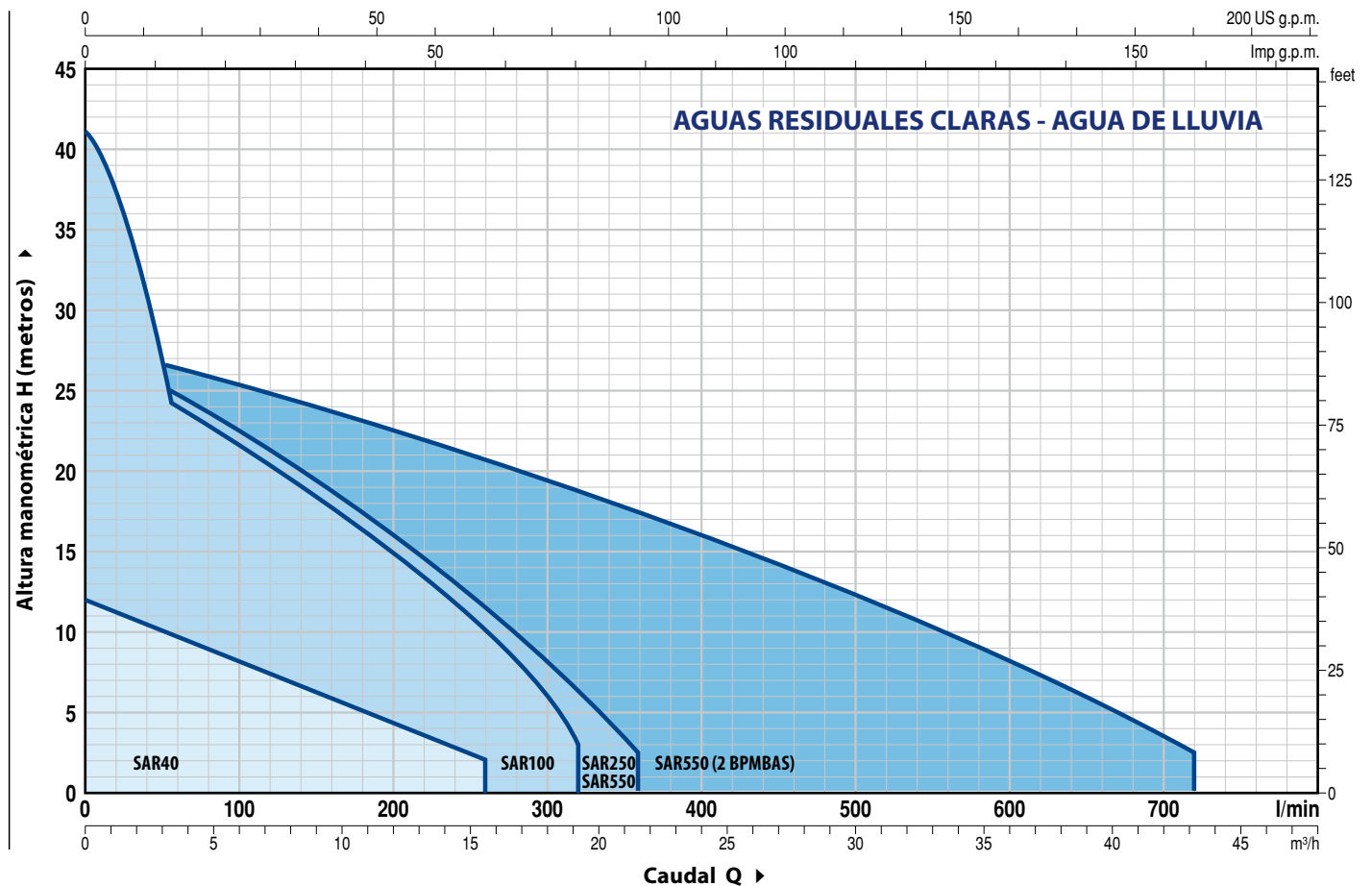



CAMPO DE PRESTACIONES

50 Hz n= 2900 min⁻¹

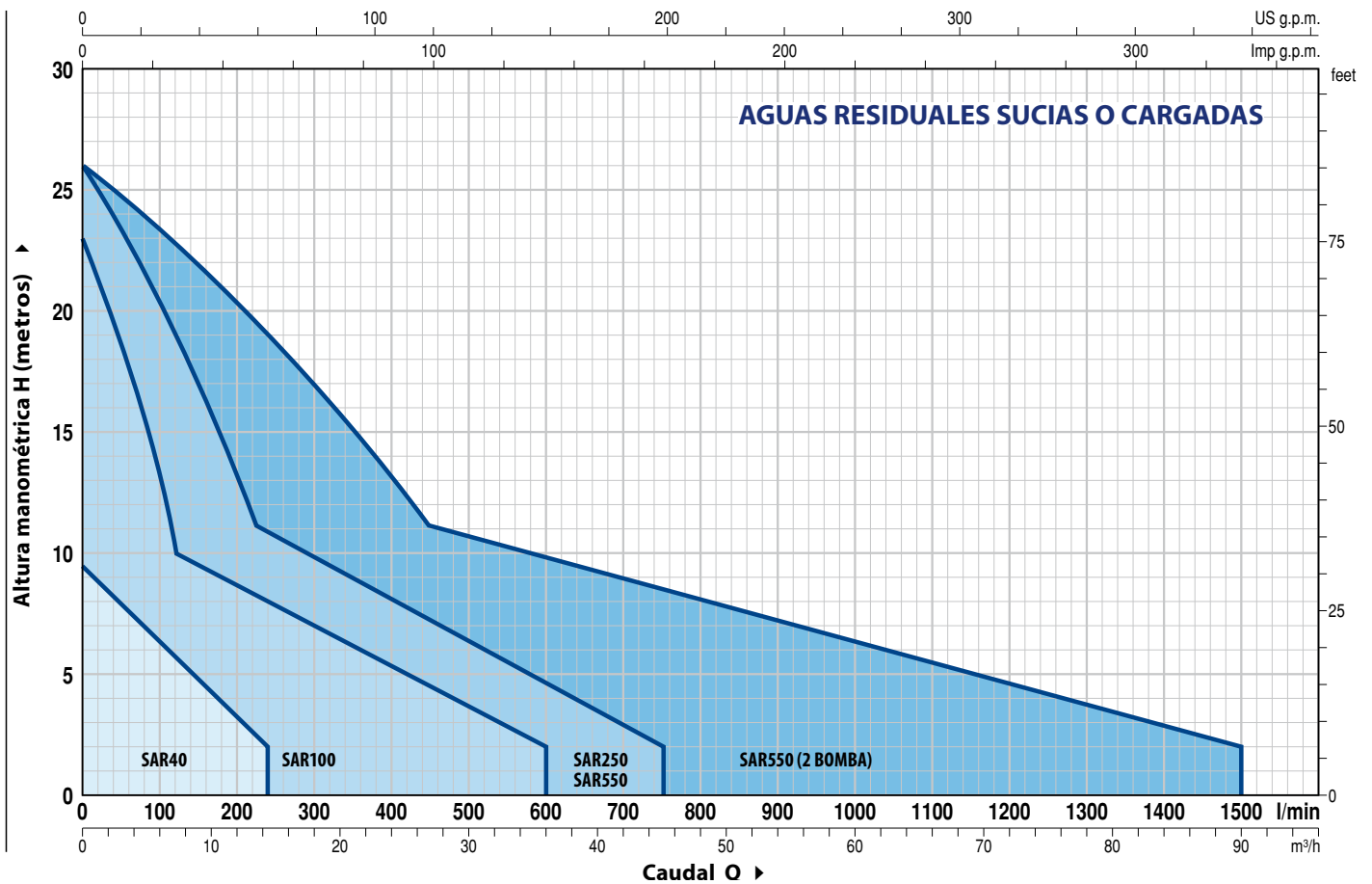

SAR 40



AGUAS RESIDUALES CLARAS - AGUA DE LLUVIA

MODELO	POTENCIA (P ₂)		DEPOSITO litros	CAUDAL MAX litros/min	ALTURA MAX metros
	kW	HP			
SAR 40 - TOP 1	0.25	0.33	40	160	6
SAR 40 - TOP 2	0.37	0.50	40	220	8
SAR 40 - TOP 3	0.55	0.75	40	260	10
SAR 40 - RXm 1	0.25	0.33	40	160	6.5
SAR 40 - RXm 2	0.37	0.50	40	220	9.5
SAR 40 - RXm 3	0.55	0.75	40	220	11.5

AGUAS RESIDUALES SUCIAS O CARGADAS

MODELO	POTENCIA (P ₂)		DEPOSITO litros	CAUDAL MAX litros/min	ALTURA MAX metros
	kW	HP			
SAR 40 - TOP 2-VORTEX	0.37	0.50	40	180	6.5
SAR 40 - TEX 2	0.37	0.50	40	200	7.5
SAR 40 - TEX 3	0.55	0.75	40	240	9.5
SAR 40 - RXm2/20	0.37	0.50	40	180	6.5

COMPONENTES

- Tanque en polietileno de **40 litros** con dos tapas
- Electrobomba completa con interruptor de flotador
- Cable de alimentación: dotación estándar 5 metros con conector Schuko (para el utilizo en el exterior la normativa EN 60335-2-41 prescribe el cable de 10 metros)
- Válvula antiretorno
- Unidad de recogida con tubo de entrada 1½" gas, de salida 1¼" gas y de respiro ½" gas

SAR 100



AGUAS RESIDUALES CLARAS - AGUA DE LLUVIA

MODELO	POTENCIA (P ₂)		DEPOSITO litros	CAUDAL MAX litros/min	ALTURA MAX metros
	kW	HP			
SAR 100 - TOP 2	0.37	0.50	100	220	8
SAR 100 - TOP 3	0.55	0.75	100	260	10
SAR 100 - TOP 4	0.75	1	100	320	12.5
SAR 100 - TOP MULTI 1	0.37	0.50	100	70	25
SAR 100 - TOP MULTI 2	0.55	0.75	100	80	40
SAR 100 - TOP MULTI 3	0.55	0.75	100	120	32
SAR 100 - RXm 2	0.37	0.50	100	220	9.5
SAR 100 - RXm 3	0.55	0.75	100	220	11.5
SAR 100 - Dm 10	0.75	1	100	300	15.5
SAR 100 - Dm 20	0.75	1	100	250	19
SAR 100 - Dm 30	1.1	1.5	100	275	26

AGUAS RESIDUALES SUCIAS O CARGADAS

MODELO	POTENCIA (P ₂)		DEPOSITO litros	CAUDAL MAX litros/min	ALTURA MAX metros
	kW	HP			
SAR 100 - TOP 2-VORTEX	0.37	0.50	100	180	6.5
SAR 100 - TOP 3-VORTEX	0.55	0.75	100	180	8
SAR 100 - RXm 2/20	0.37	0.50	100	180	6.5
SAR 100 - RXm 3/20	0.55	0.75	100	180	8
SAR 100 - ZXm 2/30	0.55	0.75	100	320	12.5
SAR 100 - ZXm 2/40	0.55	0.75	100	400	11
SAR 100 - VXm 8/35	0.55	0.75	100	350	8
SAR 100 - VXm 10/35	0.75	1	100	400	10
SAR 100 - VXm 8/50	0.55	0.75	100	450	6
SAR 100 - VXm 10/50	0.75	1	100	550	8.5
SAR 100 - BCm 10/50	0.75	1	100	600	11

SAR 100 ELECTROBOMBAS CON TRITURADOR (TRITUS)

SAR 100 - TRm 0.75	0.75	1	100	120	15.5
SAR 100 - TRm 1.1	1.1	1.5	100	120	22

COMPONENTES

- Tanque en polietileno de **100 litros** con dos tapas
- Electrobomba completa con interruptor de flotador
- Cable de alimentación: dotación estándar 10 metros con conector Schuko
- Cuadro eléctrico (solo para SAR 100-TR)
- Unidad de recogida con tubo de entrada Ø 110 mm, de salida 1¼" o 1½" o 2" gas y de respiro Ø 50 mm

SAR 250

AGUAS RESIDUALES CLARAS - AGUA DE LLUVIA

MODELO	POTENCIA (P ₂)		DEPOSITO litros	CAUDAL MAX litros/min	ALTURA MAX metros
	kW	HP			
SAR 250 - TOP 3	0.55	0.75	250	260	10
SAR 250 - TOP 4	0.75	1	250	320	12.5
SAR 250 - TOP 5	0.92	1.25	250	360	15
SAR 250 - RXm 3	0.55	0.75	250	220	11.5
SAR 250 - RXm 4	0.75	1	250	260	15
SAR 250 - RXm 5	1.1	1.5	250	300	19.5
SAR 250 - Dm 10	0.75	1	250	300	15.5
SAR 250 - Dm 20	0.75	1	250	250	19
SAR 250 - Dm 30	1.1	1.5	250	275	26



AGUAS RESIDUALES SUCIAS O CARGADAS

MODELO	POTENCIA (P ₂)		DEPOSITO litros	CAUDAL MAX litros/min	ALTURA MAX metros
	kW	HP			
SAR 250 - TOP 2-VORTEX	0.37	0.50	250	180	6.5
SAR 250 - TOP 3-VORTEX	0.55	0.75	250	180	8
SAR 250 - RXm 3/20	0.55	0.75	250	180	8
SAR 250 - RXm 4/40	0.75	1	250	280	9.5
SAR 250 - RXm 5/40	1.1	1.5	250	380	12.5
SAR 250 - VXm10/35-ST	0.75	1	250	400	10.5
SAR 250 - VXm10/50-ST	0.75	1	250	550	9.5
SAR 250 - BCm 10/50-ST	0.75	1	250	600	11
SAR 250 - VXm 10/35	0.75	1	250	400	10
SAR 250 - VXm 15/35	1.1	1.5	250	500	13.5
SAR 250 - VXm 10/50	0.75	1	250	550	8.5
SAR 250 - VXm 15/50	1.1	1.5	250	650	11
SAR 250 - BCm 10/50	0.75	1	250	600	11
SAR 250 - BCm 15/50	1.1	1.5	250	750	14

SAR 250 ELECTROBOMBAS CON TRITURADOR (TRITUS)

SAR 250 - TRm 0.75	0.75	1	250	120	15.5
SAR 250 - TRm 1.1	1.1	1.5	250	120	22
SAR 250 - TRm 1.5	1.5	2	250	260	25

COMPONENTES

- Tanque en polietileno de **250 litros** con dos tapas
- Electrobomba completa con interruptor de flotador
- Cable de alimentación: dotación estándar 10 metros con conector Schuko
- Cuadro eléctrico (solo para SAR 250-TR)
- Unidad de recogida con tubo de entrada Ø 110 mm, de salida 1¼" o 1½" o 2" gas y de respiro DN 50 o DN 75
- Pié de acople y tubos guía para la bajada de la bomba (solo para VX-ST y BC-ST)

KIT OPCIONAL BAJO PEDIDO

- **Kit de alarma** (Cod. KSKIT-ALLARME)
El kit está compuesto de: flotador, sirena autoalimentada, cuadro eléctrico
- **KIT extensión de 300 mm** (Cod. KSKIT-308MA)
El kit está compuesto de: extensión para instalar el depósito a una profundidad mayor
- **Unidad de recogida y bombeo "SAR" con válvula de retención de bola, y válvula de bola en la tubería de descarga**

SAR 550



AGUAS RESIDUALES CLARAS - AGUA DE LLUVIA

MODELO	POTENCIA (P ₂)		DEPOSITO litros	CAUDAL MAX (1 bomba) litros/min	ALTURA MAX metros
	kW	HP			
SAR 550 - TOP 4	0.75	1	550	320	12.5
SAR 550 - TOP 5	0.92	1.25	550	360	15
SAR 550 - RXm 4	0.75	1	550	260	15
SAR 550 - RXm 5	1.1	1.5	550	300	19.5
SAR 550 - Dm 10	0.75	1	550	300	15.5
SAR 550 - Dm 20	0.75	1	550	250	19
SAR 550 - Dm 30	1.1	1.5	550	275	26



AGUAS RESIDUALES SUCIAS O CARGADAS

MODELO	POTENCIA (P ₂)		DEPOSITO litros	CAUDAL MAX (1 bomba) litros/min	ALTURA MAX metros
	kW	HP			
SAR 550 - RXm 4/40	0.75	1	550	280	9.5
SAR 550 - RXm 5/40	1.1	1.5	550	380	12.5
SAR 550 - VXm 10/35-ST	0.75	1	550	400	10.5
SAR 550 - VXm 10/50-ST	0.75	1	550	550	9.5
SAR 550 - BCm10/50-ST	0.75	1	550	600	11
SAR 550 - VXm 10/35	0.75	1	550	400	10
SAR 550 - VXm 15/35	1.1	1.5	550	500	13.5
SAR 550 - VXm 10/50	0.75	1	550	550	8.5
SAR 550 - VXm 15/50	1.1	1.5	550	650	11
SAR 550 - VX 15/50 (*)	1.1	1.5	550	650	11
SAR 550 - BCm 10/50	0.75	1	550	600	11
SAR 550 - BCm 15/50	1.1	1.5	550	750	14
SAR 550 - BC 15/50 (*)	1.1	1.5	550	750	14

SAR 550 ELECTROBOMBAS CON TRITURADOR (TRITUS)

SAR 550 - TRm 0.75	0.75	1	550	120	15.5
SAR 550 - TRm 1.1	1.1	1.5	550	120	22
SAR 550 - TR 1.1 (*)	1.1	1.5	550	120	22
SAR 550 - TRm 1.5	1.5	2	550	260	25

COMPONENTES

- Tanque en polietileno de **550 litros** con dos tapas
- Dos electrobombas monofásicas (* dos electrobombas trifásica)
- Cable de alimentación: dotación estándar 10 metros
- Cuadro eléctrico
- Tres flotadores con funciones de: 1) encendido alternado de una de las bombas, 2) máximo nivel con encendido de la segunda bomba, 3) nivel mínimo para el apagado de las bombas
- Unidad de recogida con dos tubos de ingreso Ø 110 mm, de salida 1¼" o 1½" o 2" gas y de respiro DN 50 o DN 75
- Pié de acople y tubos guía para la bajada de la bomba (solo para VX-ST y BC-ST)

KIT OPCIONAL BAJO PEDIDO

- **Kit de alarma** (Cod. KSKIT-ALLARME)
El kit está compuesto de: flotador, sirena autoalimentada, cuadro eléctrico
- **KIT extensión de 300 mm** (Cod. KSKIT-308MA)
El kit está compuesto de: extensión para instalar el depósito a una profundidad mayor
ATENCIÓN: el tanque lleva dos tapas
- **Unidad de recogida y bombeo "SAR" con válvula de retención de bola, y válvula de bola en la tubería de descarga**

SAR

DIMENSIONES Y PESOS

MODELO	BOCAS			h	kg
	I	U ⁽¹⁾	S		
SAR 40 - TOP 1	1½"	1¼"	½"	305	14.0
SAR 40 - TOP 2				14.7	
SAR 40 - TOP 3				335	16.1
SAR 40 - RXm 1				305	14.2
SAR 40 - RXm 2				15.3	
SAR 40 - RXm 3				16.9	
SAR 40 - TOP 2-VORTEX				14.6	
SAR 40 - TEX 2				335	15.8
SAR 40 - TEX 3				16.5	
SAR 40 - RXm 2/20				15.6	

⁽¹⁾ Conexion macho

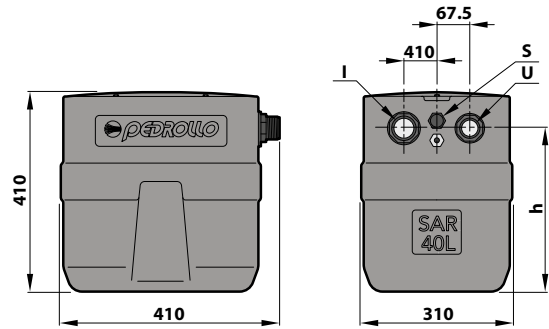

MODELO	BOCAS			i1	i2	kg
	I	U ⁽¹⁾	S			
SAR 100 - TOP 2	DN 110	1¼"	DN 50	145	100	28.7
SAR 100 - TOP 3		30.1				
SAR 100 - TOP 4		1½"				33.7
SAR 100 - TOP MULTI 1		30.3				
SAR 100 - TOP MULTI 2		32.9				
SAR 100 - TOP MULTI 3		1¼"				32.9
SAR 100 - RXm 2		29.3				
SAR 100 - RXm 3		29.6				
SAR 100 - Dm 10		36.6				
SAR 100 - Dm 20		1½"				36.6
SAR 100 - Dm 30		38.6				
SAR 100 - TOP 2-VORTEX		28.7				
SAR 100 - TOP 3-VORTEX		1¼"				30.1
SAR 100 - RXm 2/20		29.6				
SAR 100 - RXm 3/20		29.8				
SAR 100 - ZXm 2/30		29.6				
SAR 100 - ZXm 2/40		1½"				30.4
SAR 100 - VXm 8/35		36.4				
SAR 100 - VXm 10/35		37.2				
SAR 100 - VXm 8/50		36.9				
SAR 100 - VXm 10/50	2"	37.7				
SAR 100 - BCm 10/50	38.4					
SAR 100 - TRm 0.75	1¼"	46.0				
SAR 100 - TRm 1.1	47.6					

⁽¹⁾ Conexion macho

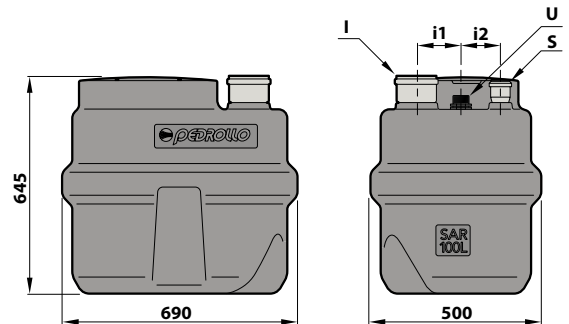

DIMENSIONES Y PESOS

MODELO	BOCAS			kg	
	I	U ⁽¹⁾	S		
SAR 250 - TOP 3	DN 110	1¼"	DN 50	42.6	
SAR 250 - TOP 4		1½"		46.2	
SAR 250 - TOP 5		1½"		46.2	
SAR 250 - RXm 3		1¼"		47.0	
SAR 250 - RXm 4		1½"		50.0	
SAR 250 - RXm 5				51.0	
SAR 250 - Dm 10				51.2	
SAR 250 - Dm 20				53.5	
SAR 250 - Dm 30				51.2	
SAR 250 - TOP 2-VORTEX				1¼"	44.0
SAR 250 - TOP 3-VORTEX					46.0
SAR 250 - RXm 3/20		1½"		45.0	
SAR 250 - RXm 4/40				53.0	
SAR 250 - RXm 5/40		53.0			
SAR 250 - VXm10/35-ST		2"		60.0	
SAR 250 - VXm10/50-ST				60.0	
SAR 250 - BCm10/50-ST		1½"		60.5	
SAR 250 - VXm 10/35				53.0	
SAR 250 - VXm 15/35		2"		54.0	
SAR 250 - VXm 10/50				53.0	
SAR 250 - VXm 15/50	DN 75	53.0			
SAR 250 - BCm 10/50		53.5			
SAR 250 - BCm 15/50	1¼"	55.0			
SAR 250 - TRm 0.75		62.0			
SAR 250 - TRm 1.1	DN 50	64.0			
SAR 250 - TRm 1.5		1½"	79.0		

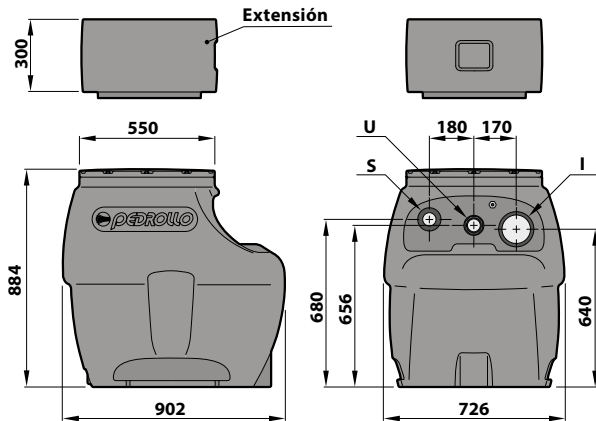

Sólo para versiones VX-ST, BC-ST

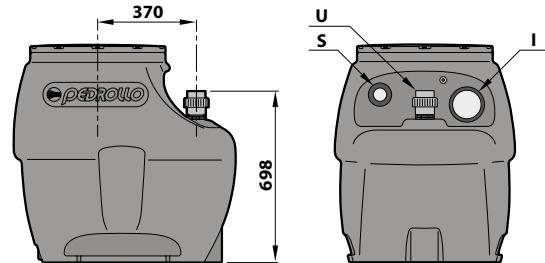

⁽¹⁾ Conexión macho (hembra para VX-ST y BC-ST)

MODELO	BOCAS			kg
	I	U ⁽¹⁾	S	
SAR 550 - TOP 4	DN 110	1½"	DN 50	96.0
SAR 550 - TOP 5				95.2
SAR 550 - RXm 4				103.0
SAR 550 - RXm 5				105.0
SAR 550 - Dm 10				101.2
SAR 550 - Dm 20				101.2
SAR 550 - Dm 30				105.7
SAR 550 - RXm 4/40				105.0
SAR 550 - RXm 5/40				106.0
SAR 550 - VXm 10/35-ST				2"
SAR 550 - VXm 10/50-ST		121.0		
SAR 550 - BCm10/50-ST		1½"	DN 75	122.0
SAR 550 - VXm 10/35				105.0
SAR 550 - VXm 15/35		2"	DN 75	106.0
SAR 550 - VXm 10/50				105.1
SAR 550 - VXm 15/50		DN 50	108.0	
SAR 550 - VX 15/50			107.0	
SAR 550 - BCm 10/50		1¼"	DN 50	109.0
SAR 550 - BCm 15/50				108.0
SAR 550 - BC 15/50		1½"	DN 50	106.0
SAR 550 - TRm 0.75	135.0			
SAR 550 - TRm 1.1	137.5			
SAR 550 - TR 1.1	137.0			
SAR 550 - TRm 1.5	182.0			

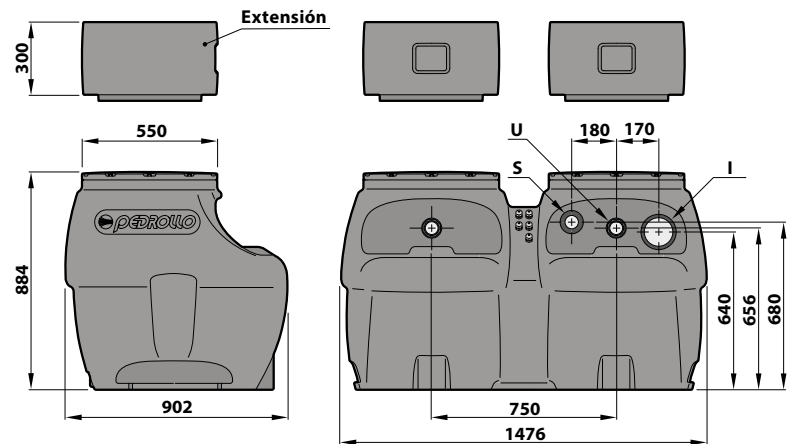

Sólo para versiones VX-ST, BC-ST

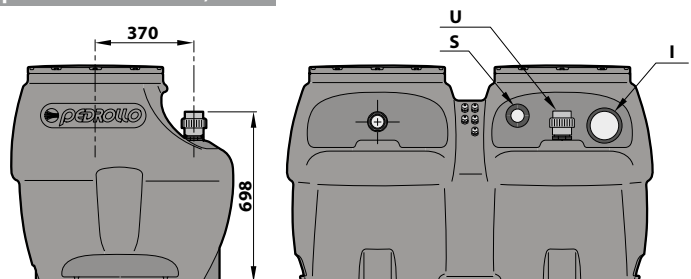

⁽¹⁾ Conexión macho (hembra para VX-ST y BC-ST)