

ELECTROBOMBAS CENTRÍFUGAS NORMALIZADAS "EN 733"

50 Hz $n=2900 \text{ min}^{-1}$



Agua limpia



Uso
industrial

CAMPO DE PRESTACIONES:

- Caudal hasta 6000 l/min (360 m³/h)
- Altura manométrica hasta 98 m

LÍMITES DE USO:

- Altura de aspiración manométrica hasta 7 m
- Temperatura del líquido de -10 °C hasta +90 °C
- Temperatura ambiente de -10 °C hasta +40 °C
- Presión máxima en el cuerpo bomba 10 bar (PN10)
- Funcionamiento continuo S1

EJECUCION Y NORMAS DE SEGURIDAD:

- EN 60335-1
- EN 60034-1
- IEC 60335-1
- IEC 60034-1
- CEI 61-150
- CEI 2-3



Dimensiones del cuerpo de la bomba conformes a la norma **EN 733 REGLAMENTO (UE) N. 547/2012**

CERTIFICACIONES:

Empresa con sistema de gestión certificado
DNV ISO 9001: CALIDAD



USOS E INSTALACIONES:

- Abastecimiento hídrico
- Instalaciones de lavado
- Presurización
- Instalaciones Anti Incendio
- Irrigación
- Industria
- Circulación del agua
- Agricultura en instalaciones de climatización



La instalación se debe realizar en lugares cerrados, bien aireados y protegidos de la intemperie.

EJECUCION BAJO PEDIDO:

- KIT contrabridas completo de tornillos, tuercas y juntas
- Sello mecánico especial
- Otros voltajes o frecuencia 60 Hz
- Para líquidos con temperaturas más altas o más bajas
- Para ambientes con temperaturas más altas o más bajas

CAMPO DE PRESTACIONES:

50 Hz n = 2900 min⁻¹

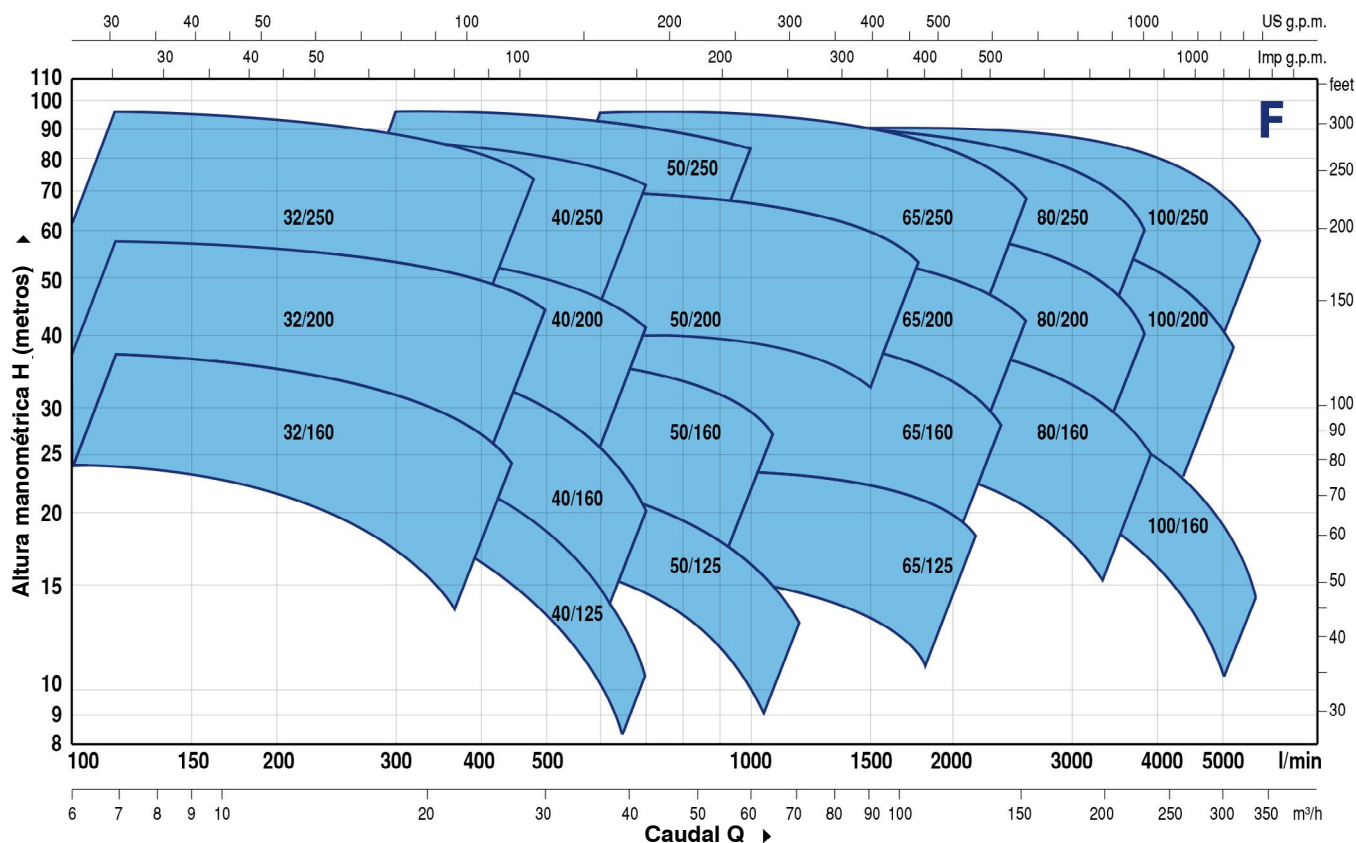

DATOS DE PRESTACIONES:

CÓDIGO	MODELO	POTENCIA (P2)		▲	PRESTACIONES	
		kW	HP		Q l/min	H metros
AC43581	F 32/160C	1.5	2	IE3	100 - 350	24 - 14
AC43582	F 32/160B	2.2	3		100 - 400	30 - 17
AC43583	F 32/160A	3	4		100 - 450	37 - 24
AC43584	F 32/200C	4	5.5		100 - 450	44 - 31.5
AC43585	F 32/200B	5.5	7.5		100 - 500	51 - 36
AC43586	F 32/200A	7.5	10		100 - 500	57 - 44
AC43587	F 32/200BH	3	4		100 - 300	45 - 37
AC43588	F 32/200AH	4	5.5		100 - 320	55 - 44
AC43589	F 32/250C	9.2	12.5		100 - 450	75 - 60
AC43590	F 32/250B	11	15		100 - 500	87 - 70
AC43591	F 32/250A	15	20	100 - 500	97 - 80	
AC43595	F 40/125C	1.1	1.5	IE3	100 - 550	16 - 6
AC43596	F 40/125B	1.5	2		100 - 600	20.5 - 9
AC43597	F 40/125A	2.2	3		100 - 700	26 - 10
AC43598	F 40/160C	2.2	3		100 - 600	27 - 14
AC43599	F 40/160B	3	4		100 - 600	32 - 20
AC43600	F 40/160A	4	5.5		100 - 700	38 - 20
AC43601	F 40/200B	5.5	7.5		100 - 700	47 - 28
AC43602	F 40/200A	7.5	10		100 - 700	55 - 41
AC43603	F 40/250C	9.2	12.5		100 - 700	64 - 47
AC43604	F 40/250B	11	15		100 - 700	71 - 55
AC43605	F 40/250A	15	20	100 - 700	88 - 72	
AC43609	F 50/125C	2.2	3	IE3	300 - 1200	17.5 - 6
AC43610	F 50/125B	3	4		300 - 1200	20.7 - 9
AC43611	F 50/125A	4	5.5		300 - 1200	23.5 - 13
AC43612	F 50/160C	4	5.5		300 - 1000	27 - 16
AC43613	F 50/160B	5.5	7.5		300 - 1100	32 - 21
AC43614	F 50/160A	7.5	10		300 - 1100	37 - 27
AC43615	F 50/200C	11	15		400 - 1700	44 - 30
AC43616	F 50/200B	15	20		400 - 1700	52 - 38
AC43617	F 50/200A	18.5	25		400 - 1800	61 - 45
AC43618	F 50/200AR	22	30		400 - 1800	69 - 53
AC43619	F 50/250D	9.2	12.5	IE3	300 - 900	51 - 32
AC43620	F 50/250C	11	15		300 - 900	59 - 42
AC43621	F 50/250B	15	20		300 - 1000	72 - 59
AC43622	F 50/250A	18.5	25		300 - 1000	85 - 73
AC43623	F 50/250AR	22	30		300 - 1000	95 - 83

CÓDIGO	MODELO	POTENCIA (P2)		▲	PRESTACIONES		
		kW	HP		Q l/min	H metros	
AC43624	F 65/125C	4	5.5	IE3	600 - 1800	16 - 11	
AC43625	F 65/125B	5.5	7.5		600 - 2000	18 - 13	
AC43626	F 65/125A	7.5	10		600 - 2200	23 - 18	
AC43627	F 65/160C	9.2	12.5		600 - 2200	32 - 22	
AC43628	F 65/160B	11	15		600 - 2400	36.5 - 23	
AC43629	F 65/160A	15	20		600 - 2400	40.5 - 28	
AC43630	F 65/200B	15	20		200 - 2400	44 - 30.5	
AC43631	F 65/200A	18.5	25		200 - 2500	50 - 36.5	
AC43632	F 65/200AR	22	30		200 - 2600	57 - 42	
AC43633	F 65/250C	30	40		400 - 2350	76 - 53	
AC43634	F 65/250B	37	50	400 - 2500	87 - 62		
AC43635	F 65/250A	45	60	400 - 2600	95 - 68		
AC43636	F 80/160D	11	15	IE3	500 - 4000	25 - 10	
AC43637	F 80/160C	15	20		500 - 4000	30 - 15	
AC43638	F 80/160B	18.5	25		500 - 4000	35 - 20	
AC43639	F 80/160A	22	30		500 - 4000	40 - 25	
AC43640	F 80/200B	30	40		500 - 3650	56 - 34.5	
AC43641	F 80/200A	37	50		500 - 3900	62 - 40	
AC43642	F 80/250B	45	60		600 - 3600	77 - 54	
AC43643	F 80/250A	55	75		600 - 3900	88.5 - 60	
AC43644	F 100/160C	15	20		IE3	1000 - 5000	30 - 12
AC43645	F 100/160B	18.5	25			1000 - 5200	34 - 14.5
AC43646	F 100/160A	22	30	1000 - 5500		38 - 17.5	
AC43647	F 100/200C	30	40	833 - 4650		51 - 28	
AC43648	F 100/200B	37	50	833 - 4900		57 - 33	
AC43649	F 100/200A	45	60	833 - 5250		63 - 38	
AC43650	F 100/250B	55	75	800 - 5150		75 - 48	
AC43651	F 100/250A	75	100	800 - 5750		89 - 58	

Q = Caudal

H = Altura manométrica total

Tolerancia de las curvas de prestación según EN ISO 9906 Grado 3B.

▲ Clase de rendimiento del motor trifásico (IEC 60034-30-1)

CURVAS Y DATOS DE PRESTACIONES F50/250:

50 Hz n= 2900 min⁻¹ HS= 0 m

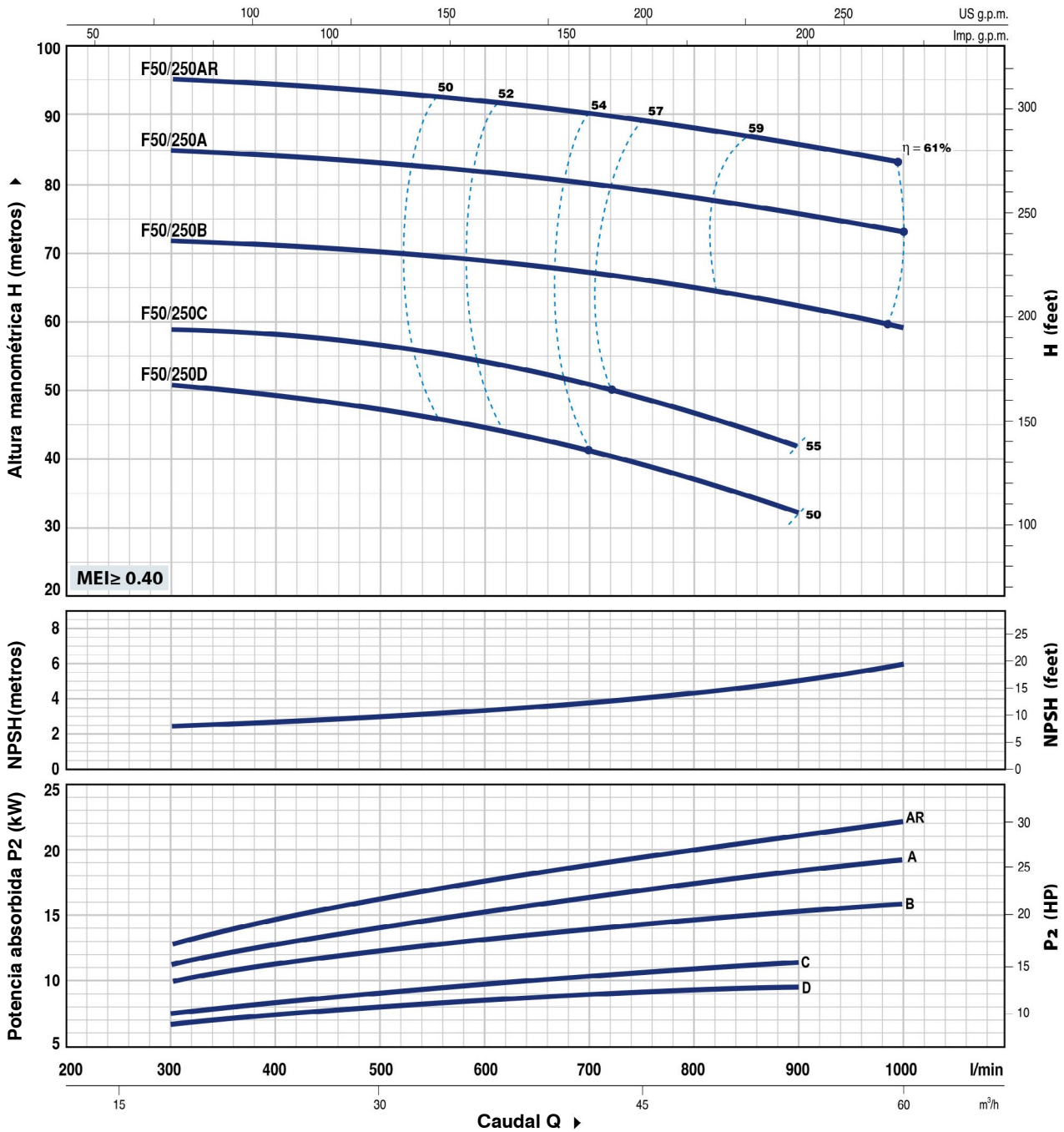

CÓDIGO	MODELO	POTENCIA (P2)		Q	Caudal Q												
		kW	HP		m³/h	0	18	24	30	36	42	48	54	60			
Trifásica					0	300	400	500	600	700	800	900	1000				
AC43619	F 50/250D	9.2	12.5	H metros	51	51	49	47	44	41	37	32	-				
AC43620	F 50/250C	11	15		59	59	58	57	54	51	47	42	-				
AC43621	F 50/250B	15	20		72	72	71	70	69	67	65	62	59				
AC43622	F 50/250A	18.5	25		85	85	84	83	82	80	78	76	73				
AC43623	F 50/250AR	22	30		95	95	94	93	92	90	88	86	83				

Q =Caudal H =Altura manométrica total HS = Altura de aspiración

Tolerancia de las curvas de prestación según EN ISO 9906 Grado 3B.

POS. COMPONENTE CARACTERISTICAS CONSTRUCTIVAS

1 CUERPO BOMBA	Hierro fundido con bocas de aspiración e impulsión con bridas
2a TAPA	Hierro fundido para F32/160, F32/200, F40/125, F40/160, F40/200, F50/125, F50/160, F65/125
2b SOPORTE	Hierro fundido para F32/250, F40/250, F50/200, F50/250, F65/160, F65/200, F65/250, F80/160, F80/200, F80/250, F100/160, F100/200, F100/250
3 RODETE	Latón para F32/160, F32/200, F40/125, F40/160, F40/200, F50/125, F50/160 Hierro fundido para F32/250, F40/250, F50/200, F50/250, F65/125, F65/160, F65/200, F65/250, F80/160, F80/200, F80/250, F100/160, F100/200, F100/250

4 EJE MOTOR Acero inoxidable AISI 431

5 SELLO MECÁNICO	Electrobomba	Sello	Eje	Materiales		
	Modelo	Modelo	Diámetro	Anillo fijo	Anillo móvil	Elastómero
	F32/160, F40/125, F40/160, F50/125	FN-20	Ø20 mm	Grafito	Cerámica	NBR
	F32/200, F40/200, F50/160, F65/125	FN-24	Ø24 mm	Grafito	Cerámica	NBR
	F50/200, F65/160, F65/200, F80/160, F100/160	FN-32 UN	Ø32 mm	Grafito	Cerámica	NBR
	F32/250, F40/250, F50/250	FN-38	Ø38 mm	Grafito	Cerámica	NBR
	F65/250, F80/200, F80/250B, F100/200	FN-40 UN	Ø40 mm	Grafito	Cerámica	NBR
	F80/250A, F100/250	FH-45 UN	Ø45 mm	Grafito	Cerámica	NBR

6 RODAMIENTOS	Electrobomba	Modelo	Electrobomba	Modelo
	F32/160C	6206 ZZ-C3 / 6204 ZZ	F32/250	6310 ZZ-C3 / 6308 ZZ-C3
	F32/160B		F40/160C	
	F40/125		F50/125C	
	Fm32/160B	6206 ZZ-C3 / 6205 ZZ	F50/250	6312 ZZ-C3 / 6212 ZZ-C3
	Fm40/160C		F40/160A	
	Fm50/125C		F40/160B	
	F40/160A	6306 ZZ-C3 / 6206 ZZ-C3A	F65/200	6314 ZZ-C3 / 6313 ZZ-C3
	F50/125A		F80/200	
	F32/200	6307 ZZ-C3 / 6206 ZZ-C3	F80/250B	6312 ZZ-C3 / 6212 ZZ-C3
	F50/160		F100/200	

7 CONDENSADOR	Electrobomba	Capacidad
	Monofásica	(230V o 240V)
	Fm32/160C	45 µF - 450 VL
	Fm32/160B	70 µF - 450 VL
	Fm40/125C	31.5 µF - 450 VL
	Fm40/125B	45 µF - 450 VL
	Fm40/160C	70 µF - 450 VL
	Fm50/125C	70 µF - 450 VL

8 MOTOR ELÉCTRICO Fm: monofásica 230 V - 50 Hz con protección térmica incorporada en el bobinado (hasta 1.5 kW)
F: trifásica 230/400 V - 50 Hz hasta 4 kW
 400/690 V - 50 Hz de 5.5 a 75 kW

* Las electrobombas trifásicas están equipadas con motores de alto rendimiento en clase IE3 (IEC 60034-30)
 ** Aislamiento: clase F – Protección: IP 55

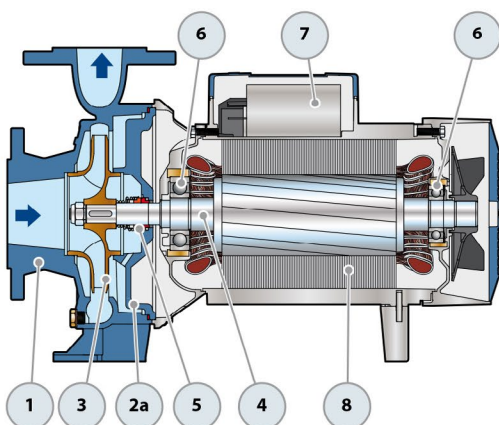

Versión monofásica

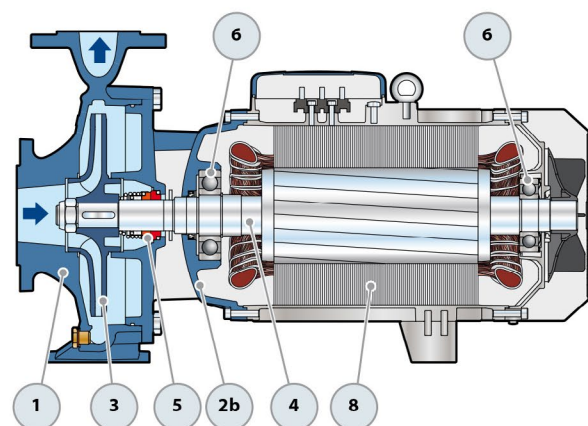

Versión trifásica

CONSUMO EN AMPERIOS

MODELO Monofásica	TENSIÓN 230 V
Fm 32/160C	11.0 A
Fm 32/160B	15.0 A
Fm 40/160C	15.0 A
Fm 50/125C	15.0 A

MODELO Trifásica	TENSIÓN	
	230-240 V	400-415 V
F 32/160C	7.5 A	4.3 A
F 32/160B	8.65 A	5.0 A
F 32/160A	12.6 A	7.3 A
F 32/200C	17.9 A	10.3 A
F 32/200B	-	11.7 A
F 32/200A	-	14.9 A
F 32/200BH	12.6 A	7.3 A
F 32/200AH	15.4 A	8.9 A
F 32/250C	-	18.5 A
F 32/250B	-	22.0 A
F 32/250A	-	25.0 A
F 40/125C	5.2 A	3.0 A
F 40/125B	7.7 A	4.5 A
F 40/125A	9.0 A	5.2 A
F 40/160C	9.9 A	5.7 A
F 40/160B	12.0 A	6.9 A
F 40/160A	17.2 A	9.9 A
F 40/200B	-	12.6 A
F 40/200A	-	15.6 A
F 40/250C	-	21.0 A
F 40/250B	-	23.5 A
F 40/250A	-	30.5 A
F 50/125C	9.4 A	5.4 A
F 50/125B	12.0 A	6.9 A
F 50/125A	16.3 A	9.4 A
F 50/160C	15.8 A	9.1 A
F 50/160B	-	12.3 A
F 50/160A	-	15.5 A
F 50/200C	-	23.0 A
F 50/200B	-	29.5 A
F 50/200A	-	34.5 A
F 50/200AR	-	41.5 A

MODELO Trifásica	TENSIÓN	
	230-240 V	400-415 V
F 50/250D	-	19.0 A
F 50/250C	-	21.0 A
F 50/250B	-	27.0 A
F 50/250A	-	34.0 A
F 50/250AR	-	41.0 A
F 65/125C	17.5 A	10.0 A
F 65/125B	-	12.0 A
F 65/125A	-	16.5 A
F 65/160C	-	19.0 A
F 65/160B	-	23.0 A
F 65/160A	-	27.5 A
F 65/200B	-	30.0 A
F 65/200A	-	34.0 A
F 65/200AR	-	41.0 A
F 65/250C	-	53.0 A
F 65/250B	-	65.0 A
F 65/250A	-	79.0 A
F 80/160D	-	22.0 A
F 80/160C	-	29.0 A
F 80/160B	-	34.5 A
F 80/160A	-	39.0 A
F 80/200B	-	53.0 A
F 80/200A	-	65.0 A
F 80/250B	-	79.0 A
F 80/250A	-	98.0 A
F 100/160C	-	27.5 A
F 100/160B	-	32.5 A
F 100/160A	-	39.8 A
F 100/200C	-	53.0 A
F 100/200B	-	65.0 A
F 100/200A	-	79.0 A
F 100/250B	-	98.0 A
F 100/250A	-	126.0 A

DIMENSIONES Y PESOS:

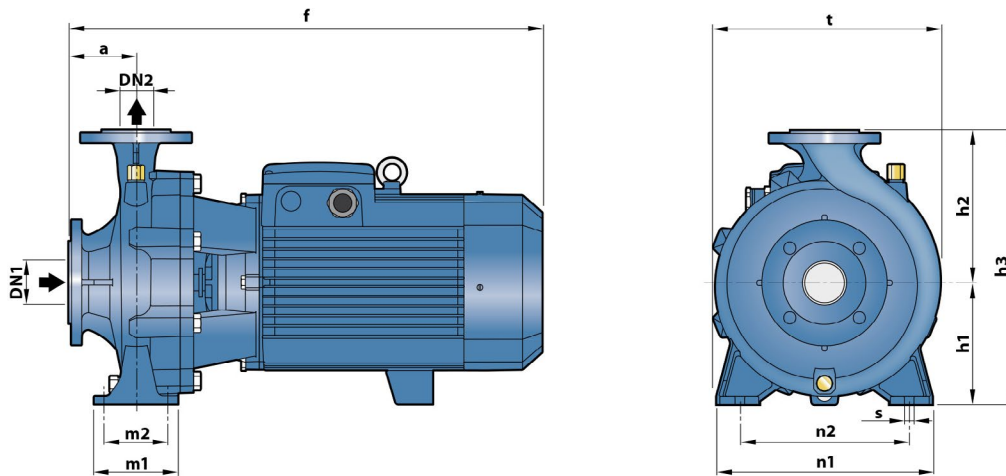

MODELO		DIMENSIONES mm													kg										
Monofásica	Trifásica	DN1	DN2	a	f	h1	h2	h3	t	n1	n2	m1	m2	s	1~	3~									
Fm 32/160C	F 32/160C	50	32	80	419	132	160	292	240	245	190	100	70	14	32.6	32.3									
Fm 32/160B	F 32/160B				448/432										42.3	35.2									
-	F 32/160A				448										-	38.7									
-	F 32/200C				469										-	46.3									
-	F 32/200B				515										-	51.8									
-	F 32/200A			515	160	180	340	273	95			70	-		56.9										
-	F 32/200BH			469	-	42.0																			
-	F 32/200AH			469	-	45.8																			
-	F 32/250C			606	180	225	405	325	320			250	125		95	-	105.5								
-	F 32/250B			701	-	103.2																			
-	F 32/250A	701	-	121.0																					
Fm 40/125C	F 40/125C	65	40	80	421	112	140	252	244	210	160	100	70	14	31.5	29.9									
Fm 40/125B	F 40/125B				441										33.0	32.4									
-	F 40/125A				439										-	32.6									
Fm 40/160C	F 40/160C				448										132	160	292	241	240	190	100	70	-	38.3	33.4
-	F 40/160B				465										-	38.9									
-	F 40/160A			465	-	43.6																			
-	F 40/200B			535	160	180	340	277	265			212	-		53.0										
-	F 40/200A			606	-	59.0																			
-	F 40/250C			606	180	225	405	329	320			250	125		95	-	104.0								
-	F 40/250B			701	-	104.0																			
-	F 40/250A	701	-	120.0																					
Fm 50/125C	F 50/125C	65	50	100	465/451	132	160	292	242	240	190	100	70	14	36.8	35.1									
-	F 50/125B				465										-	38.5									
-	F 50/125A				484										-	42.8									
-	F 50/160C				489										-	47.3									
-	F 50/160B				535										180	340	273	265	212	100	70	-	52.8		
-	F 50/160A				535										-	57.6									
-	F 50/200C				616										160	180	340	292	280	212	125	95	-	100.0	
-	F 50/200B				711										-	115.0									
-	F 50/200A				711										200	360	316.5	320	250	-	-	-	127.2		
-	F 50/200AR				743										-	141.0									
-	F 50/250D			605	-	104.2																			
-	F 50/250C			605	180	225	405	333	320	250	-	-	105.0												
-	F 50/250B			701	-	121.0																			
-	F 50/250A			701	-	134.2																			
-	F 50/250AR			733	-	147.0																			
-	F 65/125C			511	-	53.2																			
-	F 65/125B			557	160	180	340	292	280	212	125	95	-		58.3										
-	F 65/125A			557	-	63.0																			
-	F 65/160C			620	200	360	295	320	250	-	-	-	98.5												
-	F 65/160B			716	-	100.2																			
-	F 65/160A	716	-	114.0																					
-	F 65/200B	718	-	119.3																					
-	F 65/200A	718	-	132.1																					
-	F 65/200AR	751	-	145.3																					
-	F 80/160D	652	180	225	405	336	320	250	-	-	103.1														
-	F 80/160C	747	-	120.0																					
-	F 80/160B	747	-	133.8																					
-	F 80/160A	779	-	144.0																					
-	F 100/160C	760	200	280	480	382	360	280	160	120	18	-	141.2												
-	F 100/160B	790	-	150.3																					
-	F 100/160A	790	-	164.0																					

DIMENSIONES Y PESOS:

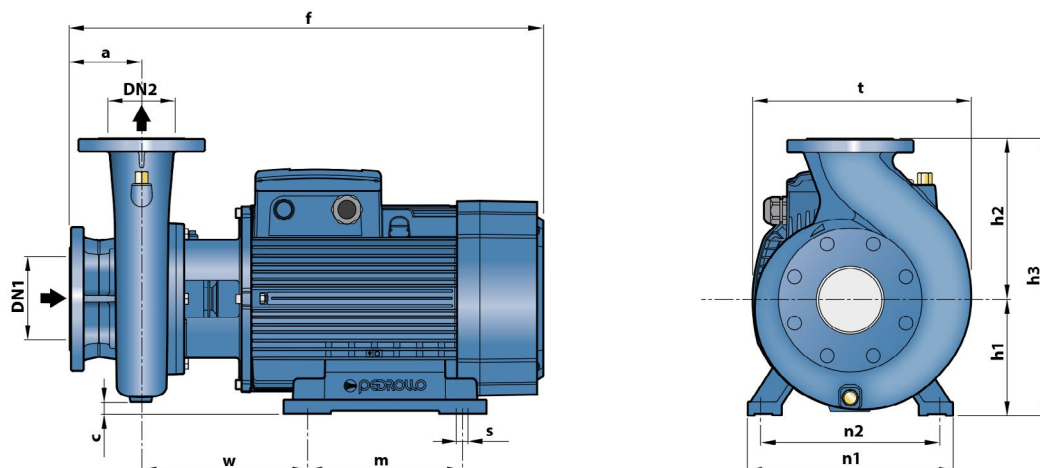

MODELO	DIMENSIONES mm														kg
Trifásica	DN1	DN2	a	f	h1	h2	h3	c	t	n1	n2	w	m	s	1~
F 65/250C	80	65	100	796	201	250	451	16	363	360	318	269.5	305	18.5	208.0
F 65/250B				847											226.0
F 65/250A				847											246.2
F 80/200B	100	80	125	824	250	280	450	26	360	490	400	294	350	24	197.4
F 80/200A				875											223.0
F 80/250B				872											240.0
F 80/250A	125	100	140	1015	250	280	620	55	490	485	406	313	350	24	547.0
F 100/200C				826											214.4
F 100/200B				875											234.2
F 100/200A	125	100	140	877	201	280	481	0	391	360	318	271	305	18.5	232.8
F 100/250B				877											551.2
F 100/250A				1060	250	280	620	40	485	485	406	313	350	24	544.3

BRIDAS DE LAS BOCAS:

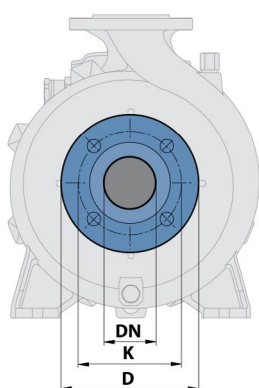

DN BRIDAS mm	D mm	K mm	ORIFICIOS	
			N°	Ø (mm)
32	140	100	4	18
40	150	110		
50	165	125		
65	185	145		
80	200	160	8	18
100	220	180		
125	250	210		

CONTRABRIDAS (se puede pedir a parte):

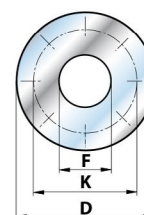

DN BRIDAS mm	F CONTRABRIDAS	D mm	K mm	ORIFICIOS	
				N°	Ø (mm)
32	1 1/4"	140	100	4	18
40	1 1/2"	150	110		
50	2"	165	125		
65	2 1/2"	185	145		
80	3"	200	160	8	18
100	4"	220	180		
125	5"	250	210		