

EXTRACTORES CENTRÍFUGOS DE CUBIERTA



Serie KUBI-MU

CARACTERÍSTICAS:

- Construido en chapa de acero
- Fácil instalación y limpieza
- Protegido contra corrosión con recubrimiento en resina epoxy
- Motor IPX4
- Tensión 230V - 50Hz
- Temperatura máx. de trabajo en continuo: 50 °C



Código	Modelo	Potencia (W)	Caudal máximo (m³/h)	Consumo (A)	r.p.m.	Toma aspiración
VE 10 382	KUBI-MU 150	98	555	0,43	2705	150
VE 10 383	KUBI-MU 200	154	950	0,67	2375	200
VE 10 380	KUBI-MU 250	194	1310	0,85	2790	250
VE 10 381	KUBI-MU 315	296	1880	1,34	2720	315

DIMENSIONES:

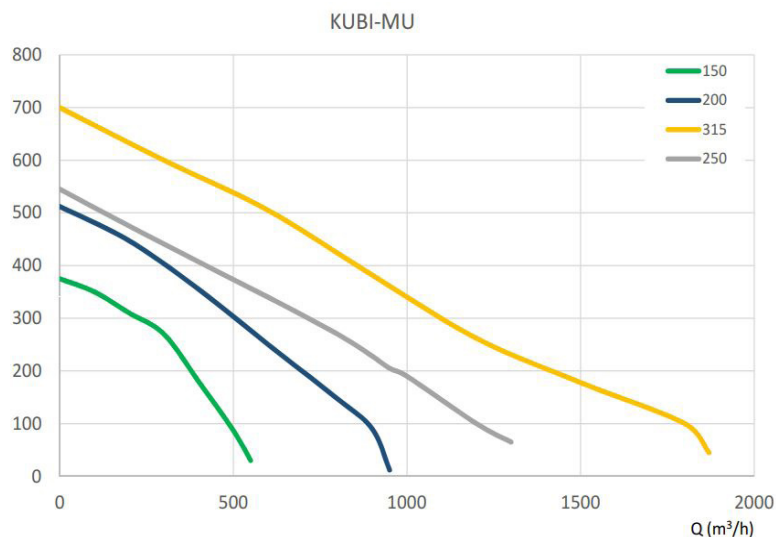
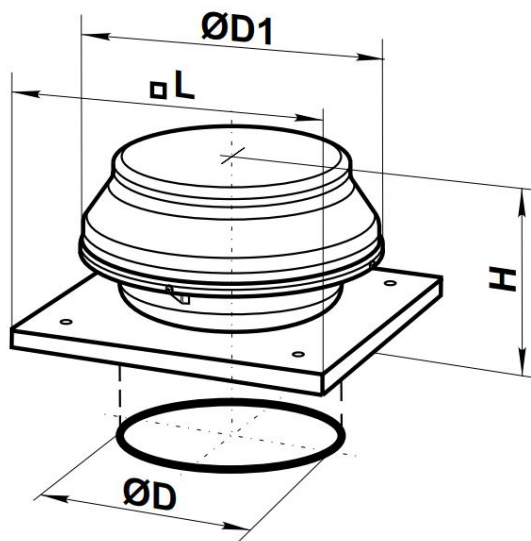

Tipo	Dimensiones [mm]				Peso [kg]
	ØD	ØD1	H	L	
KUBI-MU 150	149	400	230	440	7.2
KUBI-MU 200	198	400	250	440	8.1
KUBI-MU 250	248	400	249	590	10,1
KUBI-MU 315	315	500	339	590	12.3