

COMPENSADOR DE DILATACIÓN BRIDAS

FLANGED METAL EXPANSION COMPENSATOR

- Absorbe las dilataciones y amortigua las vibraciones en las tuberías
- Absorbs expansion and vibration in the pipes

CONDICIONES DE TRABAJO

OPERATING CONDITIONS

- Presión máx: **16 bar**
Max. pressure: 16 bar
- Temperatura: **-50° a +300°C**
Temperature: -50°C to +300°C

CONSTRUCCIÓN / MATERIAL

- **1** Fuelle: **Acero inox. AISI-304 (doble capa)**
Bellows: *Stainless steel AISI-304 (double layer)*
- **2** Bridas: **Acero al carbono**
Flanges: *Carbon steel*
- **3** Camisa interior: **Acero inox. AISI-304**
Interior sleeve: *Stainless steel AISI-304*
- **4** Tirantes: **Acero zincado**
Braces: *Zinc plated steel*
- **5** Limitador carrera: **Acero inox. AISI-304**
Stroke lim. actuator: *Stainless steel AISI-304*
- **6** Tuercas: **Acero zincado**
Threads: *Zinc plated steel*
- **7** Orejetas: **Acero al carbono**
Lugs: *Carbon steel*

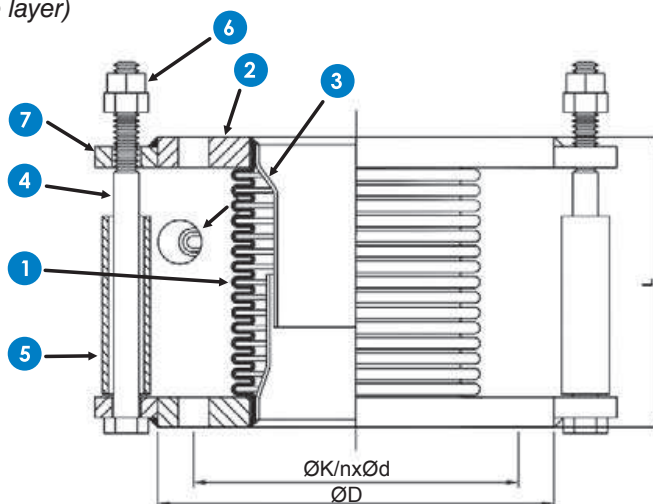

APLICACIONES / APPLICATIONS

- Refrigeración, calefacción, aire acondicionado, vapor, agua sobrecalentada, etc.
Cooling, heating, air conditioning, steam, overheated water, etc.

DIMENSIONES / DIMENSIONS

Código Code	DN		L mm	D mm	K mm	n	d	Movimiento axial (mm) Axial movement
	mm	pulg inch						
AA 13 060	32	1-1/4"	150	140	100	4	18	+10/-25
AA 13 061	40	1-1/2"	150	150	110	4	18	+10/-25
AA 13 062	50	2"	150	165	125	4	18	+10/-25
AA 13 063	65	2-1/2"	150	185	145	4	18	+10/-25
AA 13 064	80	3"	150	200	160	8	18	+10/-24
AA 13 065	100	4"	150	220	180	8	18	+10/-25
AA 13 066	125	5"	150	250	210	8	18	+10/-25
AA 13 067	150	6"	150	285	240	8	22	+10/-25
AA 13 068	200	8"	200	340	295	12	22	+15/-35
AA 13 069	250	10"	200	405	355	12	26	+15/-33
AA 13 070	300	12"	200	460	410	12	26	+15/-35