

14 **TERMOSTATO DIGITAL
DE SUPERFÍCIE**



Mundocontrol FN-42

CARACTERÍSTICAS TÉCNICAS

- Formato compacto y vertical
- Escala -50/+150° C
- Punto decimal
- Alimentación 100-240V/ 50-60Hz ±10%
- Salida 1 relé 16A Frío o Calor
- Sonda incluida PTC S6-S (silicona 1,5 m) bulbo Ø6x30 mm.
- Sonda PTC/NTC configurables
- Configurable CopyKey
- Dimensiones reducidas 122x75x34 mm
- Alarma sonora

DIMENSIONES

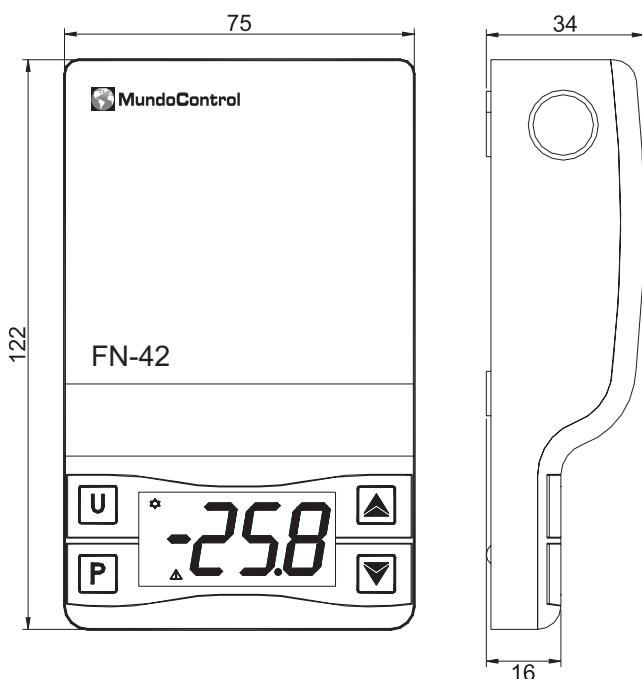

CÓDIGO CO 14 652

ESQUEMA ELÉCTRICO

