

**CIERRE I-006 FASTENER**

Conjunto automático con 2 puntos de cierre exterior posibilidad de regulación de compresión de muelles

2. External fastening points automatic kit possibility to adjust the spring pressure

Materiales y acabados:  
Aluminio gris (A)  
Composite gris (C-D)  
Interior: Composite color verde (B)  
Poliamida 6.6 natural (E-F)  
Precisar mano  
26 Tornillos: 20 de Ø 6 mm. y 6 de Ø 5 mm.  
Fuerza de cierre: 40 Kg.

Materials and finishes:  
Grey aluminium (A)  
Internal: green composite (B)  
Grey composite (C-D)  
Shock absorbing bumpers: Polyamide 6.6 (E-F)  
Left or right hand to be specified  
26 screws: 20 of Ø 6 mm. and 6 of Ø 5 mm.  
Fastening force: 40 Kg.

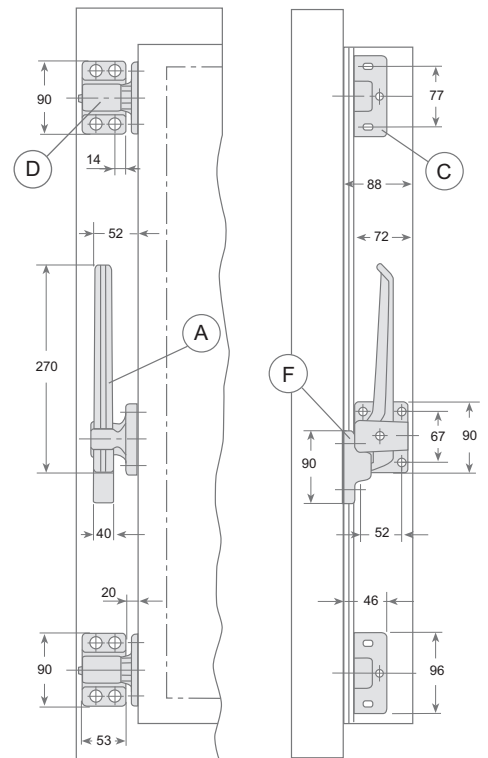
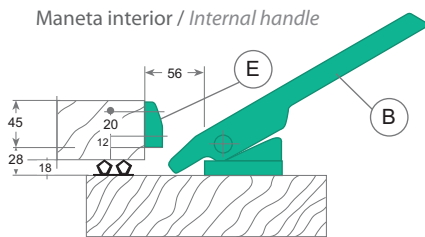

**Conjunto  
pintado**

**I-006**

Modelo Version	Código Code	Mano Hand	Peso <sup>(gr.)</sup> Weight
I-006-I	PF09059	Izquierda Left	1715
I-006-D	PF09070	Derecha Right	1715

**Enameled  
Kit**